



Owner's Manual

Dear Valued Customer,

Thank you for your purchase of a Four Winds Spa. We are sure you will have many years of enjoyment with your Four Winds Spa. Whether relaxing from a busy day, reconnecting with loved ones or just enjoying the massaging jets, you will find your mind and body are both soothed and rejuvenated.

Enclosed in this manual is valuable information on the proper installation by your Four Winds Spas Authorized Dealer, along with operating instructions and helpful tips on enjoying your new Four Winds Spa. Also, you can enter your spa's information in the Record of Ownership section on page 23 for quick reference in the future.

Also enclosed in this manual is a warranty card that should be filled out and returned to the factory. This allows us to register your purchase and enter your information into our database. Please send the completed warranty form to:

Four Winds Spas
Warranty Department
251 Mayfield Drive
Smyrna, TN 37167

(Your data will not be sold to any outside parties)

We thank you for your purchase of a Quality Four Winds Spa.

And now... Sit back and "Relax, you've earned it".

Sincerely,

The Four Winds Spas Team



Manual Overview

Page	Contents
4-8	Important Safety Instructions
9	General Guidelines Site Preparation
10	Electrical Requirements
11	Electrical Installation Instructions
12-13	Electrical Safety
14	Understanding Spa Controls and Features
15	Beginning Startup Procedures
15-16	Hot and Cold Weather Use
16-17	Troubleshooting
18	Recommendations for Maintenance
19-20	Codes, Meanings and Actions Required
21	Chemical Instructions
22	Other WARNINGS!
23	Record of Ownership

IMPORTANT SAFETY INSTRUCTIONS

1. READ AND FOLLOW ALL INSTRUCTIONS

2. **DANGER** - Do not lay across the foot well. Always sit in an upright position.
3. **WARNING** - To reduce the risk of injury, do not permit children to use this product unless they are closely supervised.
4. **CAUTION** - Water temperature may rise when jets are operating on “high” speed for extended duration.
5. A bonding lug has been provided on the outside of the Equipment Package electrical control box. The lug permits the connection of No. 8 AAWG (8.42mm²) solid copper bonding conductor between the Equipment Module and all other electrical equipment and exposed metal in the vicinity, as may be needed to comply with local regulations.
6. **WARNING** - This unit must be hardwired only to supply circuit that is protected by ground fault circuit interrupter (GFCI) see diagram. Such a GFCI is required by most building codes and should be provided by the installer and must be tested before each use. Consult GFCI manufacturers’ instructions for correct testing and operation.
7. The electrical supply for this product must include a suitable rated switch or circuit breaker to open all ungrounded supply conductors to comply with the National Electrical Codes. The disconnection means must be readily accessible to the tub occupant but installed at least 5 feet (1.5M) from spa water.
8. Spas must be installed with drainage for electrical equipment compartment.
9. Be sure the water always flows freely from the hydrotherapy jets within the spa. Any blockage or restriction to this water flow by persons or objects may damage system components, create an electrical shock hazard, and or cause water damage to the surrounding area.
10. To avoid damage to the pump(s) and heater, the Equipment must never be operated unless the spa is filled with water.

WARNING: CHILDREN SHOULD NOT USE SPAS OR HOT TUBS WITHOUT ADULT SUPERVISION

AVERTISSEMENT: NE PAS LAISSER LES ENFANTS UTILISER UNE CUVE DE RELAXATION SANS SURVEILLANCE

WARNING: DO NOT USE SPAS OR HOT TUBS UNLESS ALL SUCTION GUARDS ARE INSTALLED TO PREVENT BODY AND HAIR ENTRAPMENT

AVERTISSEMENT: POUR ÉVITER QUE LES CHEVEUX ou UNE PARTIE DU CORPS PUISSENT ÊTRE ASPIRÉS, NE PAS UTILISER UNE CUVE DE RELAXATION SI LES GRILLES DE PRISE D’ASPIRATION NE SONT PAS TOUTES EN PLACE

WARNING: PEOPLE USING MEDICATIONS AND/OR HAVING AN ADVERSE MEDICAL HISTORY SHOULD CONSULT A PHYSICIAN BEFORE USING A SPA OR HOT TUB.

AVERTISSEMENT: LES PERSONNES QUI PRENNENT DES MÉDICAMENTS ou ONT DES PROBLÈMES DE SANTÉ DEVRAIENT CONSULTER UN MÉDECIN AVANT D'UTILISER UNE CUVE DE RELAXATION

11. **WARNING** - Extreme caution must be exercised to prevent unauthorized access by children. To avoid accidents, ensure that children cannot use this spa unless they are supervised at all times.

12. **WARNINGS -WATER TEMPERATURE.** Never heat your spa water above 104 F (40 C). If you do, it could cause serious health hazards.

13. **DANGER-RISK OF ELECTRICAL SHOCK.** Install at least 5 feet (1.5m) from all metal surfaces. (A spa may be installed within 5 feet of metal surfaces if each metal surface is permanently connected by a minimum No. 8 AWG(8.4 mm²) solid copper conductor attached to the wire connector on the terminal box that is provided for this purpose.)

14. **DANGER-RISK OF ELECTRICAL SHOCK.** Do not permit any electrical appliance such as a light, telephone, radio, or television within 5 feet (1.5m) of a spa.

15. **WARNING** - Water temperature in excess of 38°C may be injurious to your health.

AVERTISSEMENT: IL PEUT ÊTRE DANGEREUX POUR LA SANTÉ DE PLONGER DANS DE L'EAU À PLUS DE 38°C.

16. **WARNING** - Pregnant or possibly pregnant women should consult a physician before using a spa or hot tub.

AVERTISSEMENT: LES FEMMES ENCEINTES, QUE LEUR GROSSESSE SOIT CONFIRMÉE ou NON, DEVRAIENT CONSULTER UN MEDECIN AVANT DI UTILISER UNE CUVE DE RELAXATION.

17. **WARNING** - Do not use a spa or hot tub immediately following strenuous exercise.

AVERTISSEMENT: NE PAS UTILISER UNE CUVE DE RELAXATION IMMÉDIATEMENT APRÈS UN EXERCICE FATIGANT.

18. **WARNING** - Prolonged immersion in a spa or hot tub may be injury to your health.

AVERTISSEMENT: L'UTILISATION PROLONGÉE D'UNE CUVE DE RELAXATION PEUT ÊTRE DANGEREUSE POUR LA SANTÉ LA.

19. **WARNING** - To avoid injury exercise care when entering or exiting the spa or hot tub.

AVERTISSEMENT: POUR ÉVITER DES BLESSURES, USER DE PRUDENCE EN ENTRANT DANS UNE CUVE DE RELAXATION ET E-.: SORTANT.

20. **DANGER – RISK OF INJURY.** The suction fittings in this spa are sized to match the specific water flow created by the pump. Should the need arise to replace the suction fittings or the pump, be sure that the flow rates are compatible. Never operate spa if the suction fittings are broken or missing. Never replace a suction fitting with one rated less than the flow rate marked on the original fitting.
21. The ideal temperature of your spa or hot tub should be between 95° and 104° F (35°- 40° C). This range is not only healthier but will also result in easier care of your spa.
22. Since excessive water temperatures have a high potential for causing fetal damage during the early months of pregnancy, pregnant or possibly pregnant women should limit spa temperatures to 100° F (38° C) or less.
23. Before entering a spa, the user should measure the water temperature with an accurate thermometer since the tolerance of water temperature regulating devices may vary as much as +/-5 degrees.
24. The use of alcohol, drugs, or medication before or during spa use may lead to unconsciousness with the possibility of drowning.
25. Persons suffering from obesity or with a medical history of heart disease, low or high blood pressure, circulatory system problems or diabetes should consult a physician before using a spa.
26. Persons using medication should consult a physician before using a spa since some medication may induce drowsiness while other medication may affect heart rate, blood pressure and circulation.
27. Because occasional users of the spa may not be aware of all the potential risk associated with spa usage, they should be made aware of these Important Safety Instructions.
28. **CHEMICAL SAFETY - Play it safe with chemicals.**
29. Maintain sanitizer level of 3-5 PPM of bromine or chlorine.
30. Do not mix chemicals with each other before adding them to the water. Add only one chemical at a time.
31. Never add concentrated liquid chemicals directly to the water. Always dilute chemicals in a large plastic bucket or pail before adding them.
32. When diluting chemicals, always add them to the water. Never add water to the chemicals.
33. Always dilute the chemical slowly and evenly before adding into the water. Never add any chemical, diluted or otherwise, into any skimmer device.
34. Always store chemicals according to the manufacturer's label directions and keep them out of reach of children.
35. A green colored terminal or a terminal marked G, GR, Ground, Grounding, or the symbol* is located inside the supply terminal box or Compartment. To reduce the risk of electric shock, this terminal must be connected to the grounding means provided in the electric supply service panel with a continuous copper wire equivalent in size to the circuit conductors supplying this equipment. *IEC Publication 417, Symbol 5019.
36. At least two lugs marked "BONDING LUGS" are provided on the external surface or on the inside of the supply terminal box or compartment. To reduce the risk of electric shock, connect the local common bonding grid in the area of the hot tub or spa to these terminals with an insulated or bare copper conductor not smaller than No. 8 AWG.

37. All field-installed metal components such as rails, ladders, drains or other similar hardware within 5' of the spa or hot tub shall be bonded to the equipment grounding bus with copper conductors not smaller than No. 8 AWG.

STEREO SPA SAFETY INSTRUCTIONS

A. **“CAUTION”** - Risk of Electric Shock. Do not leave compartment door open. Self closing door provided.

B. **“CAUTION”** - Risk of Electric Shock. Replace components only with identical components.

C. **“WARNING”** - Prevent Electrocutation. Do not connect any auxiliary components (for example cable, additional speakers, headphones, additional audio / video components, etc.) to the system.

D. Do not service this product yourself as opening or removing covers may expose you to dangerous voltage or other risk of injury. Refer all servicing to qualified service personal.

SAVE THESE INSTRUCTIONS.

Hyperthermia

WARNING: THE USE OF ALCOHOL OR DRUGS CAN GREATLY INCREASE THE RISK OF FATAL HYPERTHERMIA IN HOT TUBS AND SPAS

LA CONSOMMATION DI ALCOOL ou DE DROGUE AUGMENTE CONSIDERABLEMENT LES RISQUES D'HYPERTHERMIE MORTELLE DANS UNE CUVE DE RELAXATION.

The causes, symptoms, and effects of hyperthermia may be described as follows. Hyperthermia occurs when the internal temperature of the body reaches a level several degrees above the normal body temperature of 98.6° F (37° C).

The Symptoms of Hyperthermia Include:

- Dizziness
- Fainting
- Drowsiness
- Lethargy
- Increase in Internal Body Temperature

The Effects of Hyperthermia Include:

- Unawareness of Impending Danger
- Failure to Perceive Heat
- Failure to Recognize the Need to Exit Spa
- Physical Inability to exit Spa
- Fetal Damage in Pregnant Women
- Unconsciousness Resulting in a Danger of Drowning

General Guidelines for Site Preparation

Requirements for Access:

The size of the actual spa you choose will determine the amount of space needed to move the spa from the street to its final resting area. Be sure to measure all gate and door openings, also look for any vertical obstructions such as roof overhangs and power lines. Also consider trees, shrubs, deck railings, etc. You will need at least 1ft clear on either side of the spa.

Inside Installation:

(We do not recommend installing hot tubs inside. Any damage caused by leaks or any other concerns are not covered). If you are installing the spa indoors, make sure that there are no areas with dimension limitations such as ceilings, stairs, hallways, and walls based on the size of the spa you chose. Also make sure that the floor in the area the spa is placed will handle the weight. Water weighs just over 8 lbs (3.5 kg) per gallon so consider the filled weight of your spa including the weight of users.

Pad and Surface requirements:

We require a 3 to 4” (7.5-10 cm) completely flat reinforced concrete surface. When a spa is completely filled and has occupants, it can weigh several tons so care has to be taken when placing on any surface other than solid concrete 3 to 4” (7.5 -10 cm) thick. Therefore when placing on a deck, balcony or indoors, you must make sure that the surface can offset at least 100 lbs (45 kg) per square foot. You dealer is not usually qualified to make judgments on weight bearing abilities of structures, so always consult a qualified professional in that area of expertise.

Spa Placement

When deciding where to place the spa in the area you have available you should think of:

1. Where the electricity will come into the spa, where you will enter the area, and where you will enter the spa.
2. Will there be access to all sides of the spa for future service? Note: If you choose to place the spa in a place where any side is covered and access is limited, if you need any kind of service whether warranty or regular pay that requires additional time to gain access, you will most likely be assessed additional fees for service.
3. Also consider if you will be using a cover lift. For a side mount style, you will need about 24” (61 cm) of extra space on the side your cover will rest on. If you have limited space there are other types of lifts available to lift the cover without needing any space outside of the spa. If you are placing your spa under a roof, the space between the top of your spa and the bottom of the roof needs to be at least half of your cover plus 6” (15 cm) in order to lift off the cover. If you choose to place your spa into an area that has a structure built around it, any damage to the structure that is caused by that spa is not covered by the warranty. Example: leaks in a room that damage carpet or wood floor, etc.

You should have a disconnect at the spa for all applications which should be located within sight from equipment.

Electrical Requirements

It is the responsibility of the Spa owner to make sure that all electrical connections are made by a Qualified Electrician in accordance to the National Electrical Code and/or any local or State Electrical Codes that may be enforceable at the time of installation. All connections must be made in accordance with the wiring Diagram/ Instructions inside the Spa Control Pack.

Please have your electrician read the following instructions carefully before attempting installation of spa wiring.

*Always be sure that power is not applied to circuits while performing any electrical work.

**You can install your incoming wire anywhere in the cabinet. We recommend placing it close to the source of the incoming electricity and run it through the cabinet to the spa pack. Place a seal around the conduit placed through the hole in the side panel.

All 120 Volt capable spas require a Dedicated 15 AMP GFCI service connection. An optional 15 Amp GFCI 12ft cable is available from Four Winds Spas. Never use an extension cord to run your spa. Meeting this standard may require you to have your standard receptacle and/or circuit breaker upgraded by a Licensed Electrician. National Electrical Code 680-42

For 230 Volt spas, 1 and 2 pump spas require a Dedicated 50 AMP service and 3 and 4 pump spas require 60 AMP GFCI service connections with a 6/3 AWG (Four Wire) All Copper Conductors. National Electrical Code 422-20.

**Note: EU spas require 32 Amp R.C.D. with a 6 or 8/2 AWG (Three Wire) All Copper Conductors. Code also requires a disconnect that is readily accessible to spa users, but at least 5 feet from spa.

We recommend using 230Volt Connections in all spas that are 230Volt capable to conserve electricity by getting the most use from the heater element. All of our spa equipment is designed to operate on 60Hz alternating current. The exception is EU models that are designed to operate on 50Hz.

Electrical Installation Instructions

A copper bonding lug connector has been provided on the Spa Control Pack to allow for connection to local ground points. A 6 AWG copper ground wire is required and must be connected securely to a grounded metal structure item such as a cold water pipe or the main ground lug inside of the connecting electrical panel.

1. A green colored terminal or a terminal marked G, GR, Ground, Grounding, or the symbol * is located inside the supply terminal box or Compartment. To reduce the risk of electric shock, this terminal must be connected to the grounding means provided in the electric supply service panel with a continuous copper wire equivalent in size to the circuit conductors supplying this equipment. **IEC Publication 417, Symbol 5019.*
2. A bonding lug has been provided on the outside of the Equipment Package electrical control box. The lug permits the connection of No. 8 AWG (8.42mm²) solid copper bonding conductor between the Equipment Module and all other electrical equipment and exposed metal in the vicinity, as may be needed to comply with local regulations. 02895224
3. All field-installed metal components such as rails, ladders, drains or other similar hardware within 5 feet of the spa or hot tub shall be bonded to the equipment grounding bus with copper conductors of No. 8 AWG.
4. This unit must be hardwired only to supply circuit that is protected by ground fault circuit interrupter (GFCI). A GFCI is required by all building codes and should be provided by the installer and must be tested before use. Consult GFCI manufacturers' instructions for correct testing and operation.
5. The electrical supply for this product must include a suitable rated switch or circuit breaker to open all ungrounded supply conductors to comply with the National Electrical Codes. The disconnection means must be readily accessible to the tub occupant but installed at least 5 feet (1.5M) from spa water.
6. Spas must be installed with drainage for electrical equipment compartment.
7. Do not permit any electrical appliance such as a light, telephone, radio, or television within 5 feet (1.5m) of a spa.

***Note:** Connections made improperly, or the use of wire gauge sizes for power connection which are too small, may continually blow fuses in the spa control pack, may damage the internal electrical controls and components, and/or may be unsafe and in any case will VOID the spa Warranty.

Electrical Safety

GFCI Breaker Concerns

If the GFCI breaker will not stay engaged after you wire your spa and apply power, the GFCI breaker is not wired correctly. Check the GFCI breaker wiring chart following this section and verify that all of your connections are correct. Generally if the breaker will not stay engaged, it is a wiring problem with the neutral wire. ****Note:** The neutral and the ground wires cannot touch anywhere in between the GFCI breaker and the spa. (See wiring schematic included) The white neutral wire from the spa control system must go to the Load Neutral (bottom of breaker).

50 AMP Service for 1 - 2 Pump Spas

60 AMP Service for 3 - 4 Pump Spas

Diagram 1: USA Only

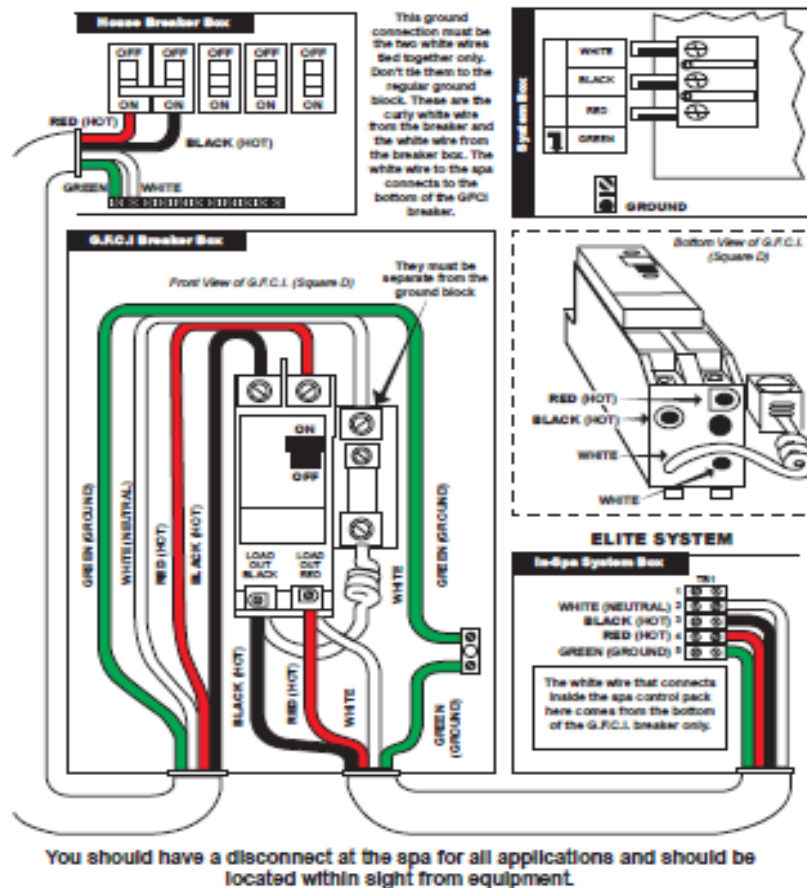

EURO Wiring Specs (50 Hz)
1 x 32 AMP Service for 1-3 Pump Spas
2x 32 AMP Service for 4 Pump Spas

32 AMP GFCI WITH A-RATED TRIPPING
CURRENT NOT EXCEEDING 30 MA.

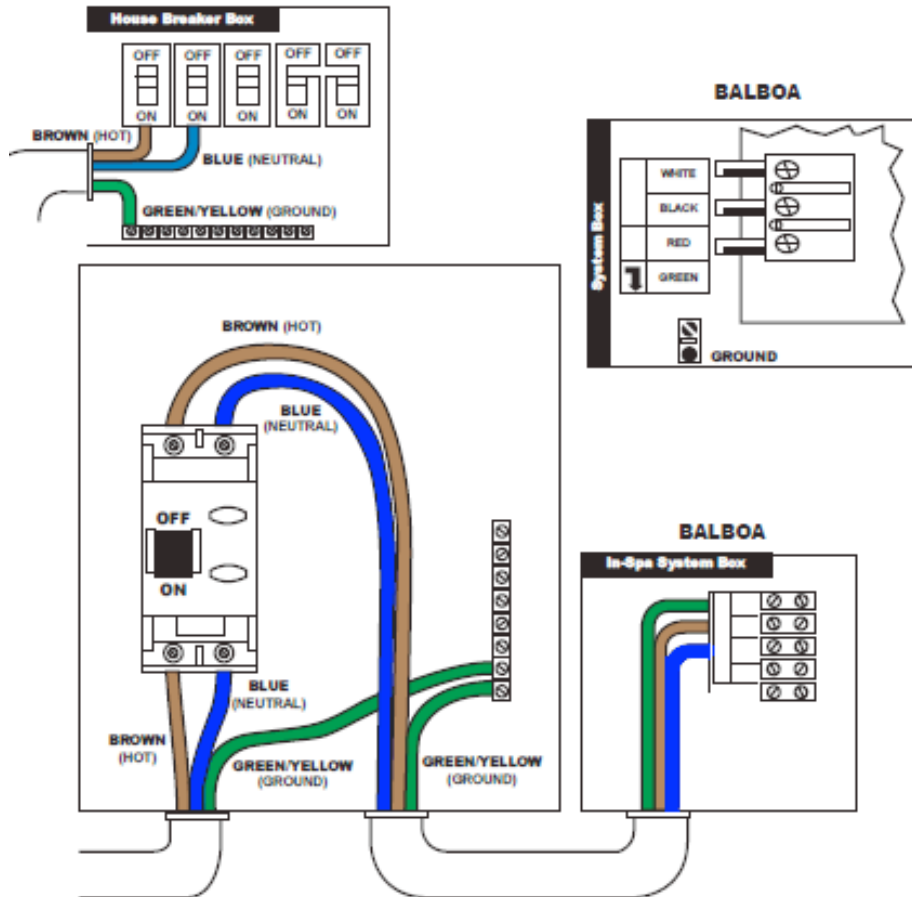

50 HZ SYSTEMS ONLY!

Servicing your spa:

Four Winds Spas does not recommend that you service this spa, but if you choose to open the spa electrical panel and service the spa yourself, always assume that there is power (230Volts) to the system, unless you have verified with a test meter that there is no power to the panel. There are generally no user serviceable parts inside this panel unless you have proper training. If you are not properly trained, call your selling dealer for service. If they will not help you, then call Four Winds Spas technical service.

Understanding Spa Controls and Features

Air Valve: This valve(s), when turned to the right, will add air to the jets that are connected to that particular valve. This extra air will add power to the jets and offer a more vigorous massage. There are generally 2 or more of these valves, each working a different set of jet seats. Some two and three pump spas may have 3 or more of these valves. When not in use, we recommend that you keep these valves closed to cut down on the chance of foaming.

Diverter Valve: The diverter valve (if equipped) splits the power of a pump between two sets of jets or a set of jets and a Master Massage jet or jets. This is a very large valve.

Bullet Style Jet: These jets offer a straight water stream and this type cannot be adjusted for direction or strength.

Main Jets: These jets come in various sizes and jet types. The single hole directional style can be adjusted to point in a particular direction and the whirly two hole style will push water out in a circular pattern. These jets can be power adjusted from full power to off by turning the outside body of the jet.

Handrail Waterfall: (If Equipped) This waterfall can be used as an access handle to assist with entrance into the spa. Caution: Do not put full body weight on the handle. It is designed to be an assist handle only.

LED Light System: (If equipped) The system offers several options including a series of steady light colors and variations of constant change in light colors. The light system has LED bulbs in each light assembly with a master light in the position of the main spa light that will also change colors with the rest of the system.

Outside Spa Drain: This drain is a small black port mounted on the bottom of the spa side panel. See the Recommendations for Periodic Maintenance below for instructions on how to operate the drain.

Beginning Startup Procedures

Once your spa is properly wired and ready to start, fill the spa up with water. Generally you will fill the spa up to the bottom of the highest set of neck jets in the spa or about 6 inches above top of the floating filter housing ring. Remember this level will rise as people get into the spa, so you just want to get the water to a level that will keep it from splashing out when people are in the spa. Next, turn the power on and watch the topside control panel for either a PR or Priming Mode feature. Press the pump button for the main 2-speed pump to test the pump for water movement. If you have water movement, press the next pump button if equipped and verify movement. Repeat the same procedure until all pumps are moving water. Then watch for the heat indicator to come on the topside.

Note: *All 110V spas or any spa set in the 15 Amp mode will only heat with the two speed pump only on low speed.*

Once the heat light is verified to be on, your spa is heating. Two and Three pump USA spas will heat about 6-9 degrees per hour. One pump USA 230V spas will heat about 4-7 degrees per hour and 120V spas will heat about 2-3 degrees per hour. One & Two pump EU spas will heat about 4-6 degrees per hour. All of these times are approximate.

If your spa has a PR or Priming Mode code on the topside, it will take 4 to 6 minutes for it to go into the regular heating mode.

Cold Weather Startup:

If your spa arrives and the environment where the spa is to be placed is 40°F or below, your **Professional Installer** will need to put a small ceramic heater or light bulb inside the spa cabinet to thaw out the water that may be left inside the pumps **BEFORE STARTING YOUR SPA**. If your Professional Installer starts the spa and all pump fuses blow, the pumps may have frozen water in them. Four Winds Spas makes every effort to remove as much water from water testing as possible before shipping, but it is impossible to remove all water from a spa plumbing system, therefore this step is crucial before starting your spa.

Hot and Cold Weather Use

Hot Weather Use:

If you choose to shut your spa down for the warmer seasons of the year you should drain as much water as possible, clean the spa shell and keep the cover in place. We recommend that you keep the spa running through this season and just turn the temperature down to a more comfortable range or change the system to sleep mode, and avoid automatic filtration between 10am and 5pm. Avoid F6, F8, FC filter cycle setting. A spa will last longer if it is allowed to run all of the time.

Cold Weather Use:

Because it is impossible to remove all water from your spa we recommend that you never shut your spa down and drain the water during the cold seasons if you live in an area where freezing would be a possibility. Freeze damage is not a covered repair. If your spa stops heating during the cold seasons, it is your responsibility to protect the spa from damage until repairs can be made. To protect your spa, you can put a heat light bulb or a small ceramic heater inside the spa cabinet and place the door back over the opening. Contact your selling dealer for recommendations for winterizing and service.

Trouble Shooting

If you need service, you should call your selling dealer first. If you are installing your spa and your electrician is still onsite they can check the information below for help.

If Your Spa Will Not Run Upon Initial Startup:

If after you wire your spa and apply power, the spa will not run or the top side control will not light, you should first have the electrician check voltage at the spa control system. It is easy to blow fuses when first wiring a new spa if you accidentally put the wires in the wrong place, or touch anything powered in the spa control pack to ground. There is a main safety fuse in the pack that is designed to protect the whole board from a miss wire. This fuse is usually a 3/10 amp fuse. (That means less than one amp) Fuses and miss wired boards are not covered by Warranty.

If a pump will not run:

You could have blown a fuse. See *Cold Weather Startup* if it's cold outside when spa is installed. Most VS series packs like the VS300 and VS501 have one pump fuse. The three pump packs like the EL2KM3 & EL8KP4&5 have three to four pump fuses. These fuses cannot be checked in the 230V circuit. Your **Professional Installer** will need to remove them and perform an "ohm" check across them.

***Note:**

These fuses can be acquired at most Lowe's or Home Depot and are SC or SLC 30.

****Four Winds Spas, or its authorized service centers will not be held responsible for damage to spa and/or components caused by improperly wired spas or any personal injury related to an owners attempt to repair a spa. Replacement costs will be the responsibility of the spa owner.**

Troubleshooting Continued

If the spa is running but not heating:

If your spa has worked and heated before with no problem and it suddenly is dropping temperature, check first to be sure you haven't accidentally put the controls in the economy mode or sleep mode. On most controls you can touch the warm button then the light or mode button, to select your 3 different modes if equipped.

ST = Standard mode – The spa will filter as set and heat as needed

EC = Economy mode – The spa will filter as set and only heat during the filtration modes

SL = Sleep mode – Will maintain 20° below set temperature during the filtration modes

****Note:** Instructions to adjust the filter cycle times is found in the Timing Your Filtration Cycle section.

If your spa is running continuously:

Check your preset filter cycle setting as you may be on a longer filtration setting than needed.

Timing your filtration cycles:

7 minutes after the power is turned on to your spa, your automatic filtration will start. It will filter on low speed for 2 hours or until water temp reaches preset level. Then 12 hours later, the spa will start its automatic filtration for another 2 hours. Overall the best time frames for filtration are 7:00 am – 9:00 am and 7:00 pm – 9:00 pm. Avoid your spas automatic filtration between 10:00 am – 5:00 pm in July and August, being it is the hottest part of the day. To set your spa filtration time to filter between certain hours first be sure you are on proper cycle, generally F2 or FIL2 then shut off the breaker to your spa and when you power up the breaker to your spa the filtration cycle will start 7 minutes later. Checking the filtration cycle can be done from your top side control by pushing the warm button once then pushing the main jet button once, this will allow you to preview what cycle you are on. If you are on a longer setting than needed push the warm button to scroll through the cycles till you return to the proper setting. The spa control system may take up to 12 hours to accept the change made or you can shut of the breaker to the spa for a minute and then power the breaker back on which will then retain the last change you made.

Three and four pump control systems allow you to set the filtration by pushing Time then Mode which allows you to set the time clock to your area. Following the time settings will be Filter 1 AM filtration, push the warm button to select AM start time of 7:00 AM push Mode save and it will proceed to Filter 1 end time of 9:00 AM then press Mode to save, follow the same instructions for the PM filter cycle and set the start time at 7:00 PM and end time at 9:00 PM. Pressing the Mode button afterwards will exit the programming and the display will return to the actual temperature reading. You do not have to shut breaker off to the spa on this system.

Recommendations for Maintenance

Chemical Maintenance:

It is very important that you maintain the correct level of chemicals in your spa. Otherwise, you run the risk of damaging the jets and the heating elements, as well as encouraging cloudy water and skin and eye irritations. Also remember that chemical damage is not covered under warranty.

Please refer to Chemical Safety Instructions at the back of the manual for further instructions.

Cover: Clean the cover with soap and water once per month to remove things like tree sap and dirt.

Side Panels: Wash the side panels periodically with water.

Spa Shell: When you change the water, wipe the shell down with Fast Orange or some other biodegradable cleaner and rinse the shell out and drain the water out or vacuum it out of the foot well.

Water: Replace the water 2 to 6 months based on your amount of use, personal preference, or dealer recommendations.

To drain your spa: Grab the handle on the cap with pliers and pull it straight out, then turn it about 1/4 turn to the left and then pull it out about 3". This will lock the tube into place so you can remove the cap and not lose any water. Then attach a water hose to the tube and push the tube in about half way and drain the water as needed. After finishing, simply pull the tube back out 1 inch, remove the hose, install the cap and push the tube back in until it stops. Then twist the tube to the right and push it the rest of the way back in to hide away.

Filter: Clean the filter once a month by backwashing with garden hose or placing it in the dishwasher but do not allow it to go through the drying cycle of dishwasher. Replace the filter once a year.

To remove your filter: Never try to remove your spa filter lid, basket or cartridge while spa pump is running. Turn spa breaker off. If you have a screw filter remove the floating weir tube and counter clock wise unscrew the filter and remove. If you have a drop in filter turn the telescopic lid counter clock wise 1/4 turn to remove, lift out the filter basket to remove filter. Reverse the process for installation. If your basket and lid will not lock, your filter cartridge is either not sitting in the housing properly or the basket is not sitting on the filter cartridge properly.

Codes, Meanings and Actions Required

<u>Code*</u>	<u>Meaning</u>	<u>Action Required</u>
None	No message on display. Power has been cut off to the spa.	The control panel will be disabled until power returns. Spa settings will be preserved until next power up.
- -	Temperature unknown.	After the pump has been running for 2 minutes, the temperature will be displayed.
HH	“Overheat” – The spa has shut down. One of the sensors has detected 118°F at the heater.	DO NOT ENTER THE WATER. Remove the spa cover and allow water to cool. Once the heater has cooled, reset by pushing any button. If spa does not reset, shut off the power to the spa and call your dealer or service organization.
OH	“Overheat” – The spa has shut down. One of the sensors has detected that the spa water is 110°F at the heater.	DO NOT ENTER THE WATER. Remove the spa cover and allow water to cool. At 107°F, the spa should automatically reset. If spa does not reset, shut off the power to the spa and call your dealer or service organization.
IC	“Ice” – Potential freeze condition detected.	No action required. The pump(s) will automatically activate regardless of spa status.
SA	Spa is shut down. The sensor that is plugged into the Sensor “A” jack is not working.	If the problem persists, contact your dealer or service organization. (May appear temporarily in an overheat situation and disappear when the heater cools.)

SB	Spa is shut down. The sensor that is plugged into the Sensor “B” jack is not working.	If the problem persists, contact your dealer or service organization. (May appear temporarily in an overheat situation and disappear when the heater cools.)
SN5	Sensors are out of balance. If alternating with spa temperature, it may just be a temporary condition. If flashing by itself, spa is shut down.	If the problem persists, contact your dealer or service organization.
HL	A significant difference between temperature sensors has been detected. This could indicate a flow problem.	Check water level in spa. Refill if necessary. If the water level is okay, make sure the pumps have been primed. If problem persists, contact your dealer or service organization.
LF	Persistent low flow problems. (Displays on the fifth occurrence of “HL” message within 24 hours.) Heater is shut down, but other spa functions continue to run normally.	Follow action required for “HL” message. Heating capability of the spa will not reset automatically; you may press any button to reset.
DR	Possible inadequate water, poor flow, or air bubbles in detected in the heater. Spa is shut down for 15 minutes.	Check water level in spa. Refill if necessary. If water level is okay, make sure the pumps have been primed. Press any button to reset, or this message will automatically reset within 15 minutes. If problem persists, contact your dealer or service organization.
DY	Inadequate water detected in heater.(Displays on third occurrence of “DR” message.) Spa is shut down.	Follow action required for “DR” message. Spa will not automatically reset. Press any button to reset.

***Note:** Not all codes pertain to all spas.

Chemical Instructions:

Important numbers of reference:

- Maintain Total Alkalinity level of 80 – 120 PPM.
- Maintain sanitizer level of 3.0 – 5.0 PPM for bromine or 1.5 – 3.0 PPM for chlorine.
- Maintain Ph level of 7.2 to 7.8.
- Maintain calcium hardness level of 100 – 250 PPM.

Recommended items to purchase:

- Ph test strips
- Spa Up and Spa Down, or Ph Balance
- Nature 2 sanitizer stick or Spa Frog sanitizing system
- Spa Defender
- Calcium Booster

It is important to first maintain the total alkalinity levels at 80 – 120 PPM. Total alkalinity is the ability to control Ph levels. To do this, you will need *Spa Up* and *Spa Down*. Once you are sure your total alkalinity levels are within the correct range, you then need to maintain correct Ph levels of 7.2 to 7.8. For this you will need *Ph test strips* and either *Spa Up* and *Spa Down* or *Ph Balance*. You should also maintain the correct sanitizer level to disinfect the spa and keep the water smelling fresh. This can be done with a *Nature 2 sanitizer stick* or *Spa Frog*. The correct sanitizer level is 3.0 – 5.0 PPM for bromine or 1.5 – 3.0 PPM for a chlorine system. You will also need to maintain your calcium hardness levels at 100 – 250 PPM. You can use your test strips to measure it. Calcium hardness is sometimes called total hardness and is simply a measure of the minerals in your water including calcium and magnesium. If you do not have enough hardness, your spa will draw from other metals such as copper, aluminum and iron in the heating elements, pump seals and internal components. If your spa has too much hardness, this will encourage scale formation and cloudy water. We recommend you fill your spa with water from a softener, especially if you think your tap water is too hard. There is no known way to decrease calcium hardness, but *Spa Defender* is a good way to prevent against scale formation. If the calcium level is too low, you can use *Calcium Booster*.

Additional notes:

1. Do not mix chemicals with each other before adding them to the water. Add only one chemical at a time.
2. Never add concentrated liquid chemicals directly to the water. Always dilute chemicals in a large plastic bucket or pail before adding them.
3. When diluting chemicals, always add them to the water. Never add water to the chemicals.
4. Always dilute the chemical slowly and evenly before adding into the water. Never add any chemical, diluted or otherwise, into any skimmer device.
5. Always store chemicals according to the manufacturer's label directions and keep them out of reach of children.
6. To maximize efficiency of chemicals, change the water in your spa every 3 months.

WARNINGS!

DANGER RISK OF PERSONAL INJURY OR DEATH

Never Operate the spa if a suction fitting, suction cover, filter, filter lid or weir assembly are broken, damaged or missing.

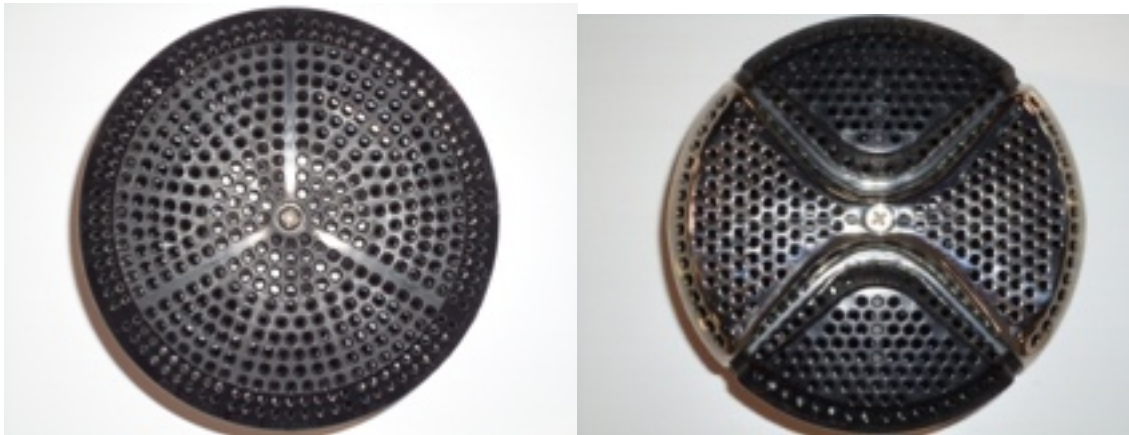

DANGER RISK OF SEVERE INJURY OR DROWNING!

Entrapment may occur if hair is entangled, knotted or snagged in a suction drain or filter lid, or weir assembly. This has been reported in persons who when submerging themselves underwater, allowing hair to come close and/or within the reach of the suction fittings, suction covers, filter, filter lid or filter weir.

Children are at risk for hair entrapment if swimming under water. Never allow children to play or get near the suction fittings, suction covers, filter, filter lid or filter weir.

DANGER DO NOT BLOCK!

DO NOT BLOCK THE SUCTION COVERS FOR ANY REASON

Four Winds XL Swim Spa Record of Ownership

Four Winds Model:	
Serial Number:	
Date Purchased:	
Dealer Name:	
Dealer Number:	
Dealer Address:	
Dealer City/State:	
Service Technician:	
Other Info:	

